

## GD29 Heavy Duty Over Centre Latch Fastener

### Features

- This robust catch incorporates a strong coil-spring which gives leveraged over-centre action against a stainless steel rod, mounted on a striker plate, with slotted mounting holes to allow for easy adjustment
- Cleverly designed as a die cast assembly for good appearance, the catch is generally used to secure fabricated covers or access doors on large earthmovers and similar applications
- Available in both locking and non-locking versions
- Base-plate is mounted on fixed member, striker plate is mounted on mating panel. The catch body is brought down so that the operating 'claw' engages with striker pin, and the pivoted lever-handle is then pressed down to achieve over-centre action, forcing panels tightly together
- Action of lever-handle extends spring-loaded plunger, holding catch tightly in position and preventing 'rattle'. On locking versions, lock cylinder secures handle against striker plate

### Material

- Steel, black powder coated

### Notes

- Completely plant-on fixing, by bolts or rivets through mounting holes (slotted for adjustment on striker plate)



**GD29-G02096**  
(Non-locking,  
with striker plate)

**GD29-G02094**  
(Locking,  
with striker plate)

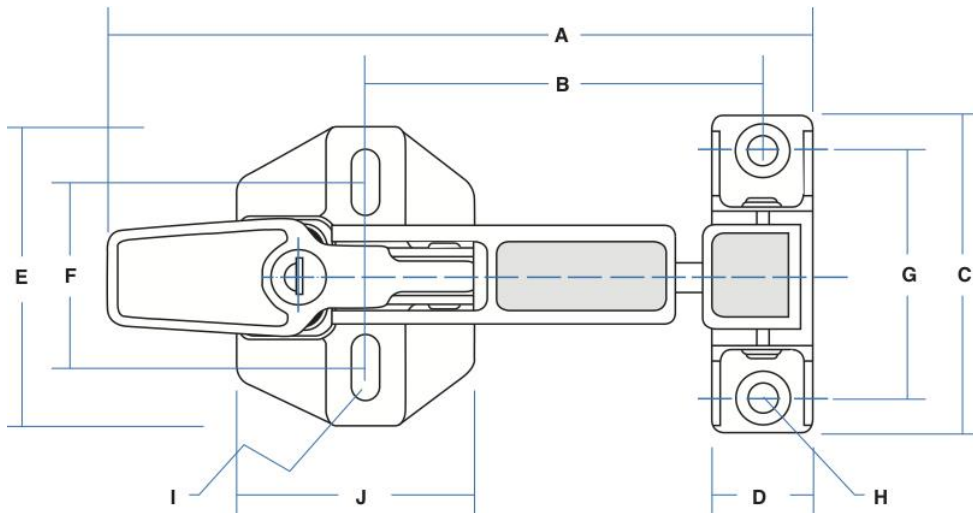

| Part No.       | Locking | Key      | A   | B   | C  | D  | E  | F  | G  | H   | I        | J  | K  |
|----------------|---------|----------|-----|-----|----|----|----|----|----|-----|----------|----|----|
| GD29-G02094    | Yes     | Standard |     |     |    |    |    |    |    |     |          |    |    |
| GD29-G02094-01 |         | FT111    | 212 | 120 | 96 | 30 | 93 | 58 | 75 | 8.5 | 8.5 x 20 | 72 | 42 |
| GD29-G02096    | No      | -        |     |     |    |    |    |    |    |     |          |    |    |